



Electromagnetic Metering Pumps

**EWN-Y**



**Upgraded Software with New  
Features & Improved Functions**

The Heart of Industry

# Electromagnetic Metering Pumps with Precise Flow Monitoring,

## Upgraded Software with New Features and Improved Functions

### NEW FEATURES

- Feedback control is now available with digital pulse signal operation in addition to analog control.  
(Flowrate feedback operation using a pulse input enables easy replacement of existing equipment.)
- Alarm output can be programmed for either normally open or normally closed operation.

The EWN-Y electromagnetic pump combined with EFS flow sensor (option) provides accurate real time control & display of dosing rate.

The required flow rate is simply input to the pump. Through feedback from the EFS sensor, the pump constantly adjusts its speed to maintain the set dosing rate - even under changing temperature or suction & discharge pressure conditions.

The EFS is mounted directly on the pump to digitally display dosing rate per minute or hour - ALL WITHOUT ANY CALIBRATION.

The EWN-Y gives a proportional 4-20mA output signal of dosing rate and displays operating history such as total flow volume and power-on time.



EWN-Y  
With EFS flow sensor (option)

# Feedback & Control

## Displaying Flow Rate

Pump flow rate may be displayed. In case the EFS flow sensor (option) is installed, the EWN-Y pump can display accurate real time flow rate without any calibration.

## Feedback Control (with EFS)

Flow rate monitoring of individual strokes by the EFS sensor enable fast response feedback control. The feedback control maintains the set capacity by manually or externally with analog input signal.

## Discharge Detection

Direct connection to the IWAKI FCP or FCM flow counter (excluding certain low- pressure models) allows effective monitoring of pump discharge (number of shots). Gas lock, abnormal pressure (only with FCP), etc., are also detectable.

## Alarm Output and Analog Output Functions are Provided as Standard Function

Two types of alarm outputs and analog output are provided as standard functions. The analog output can be used for flow rate monitoring.

## Waterproof Structure (IP65)

With the aim of improving resistance to exposure to liquid, the controller unit is installed on the back of the pump and the control panel is protected with a cover as standard equipment. A rubber gasket is provided between the pump head and the bracket to prevent water from entering from the periphery of the pump head.

## Multi Hose Connection

The use of a new hose stopper eliminates a twist in tube connection.



# Technical Data

## Construction

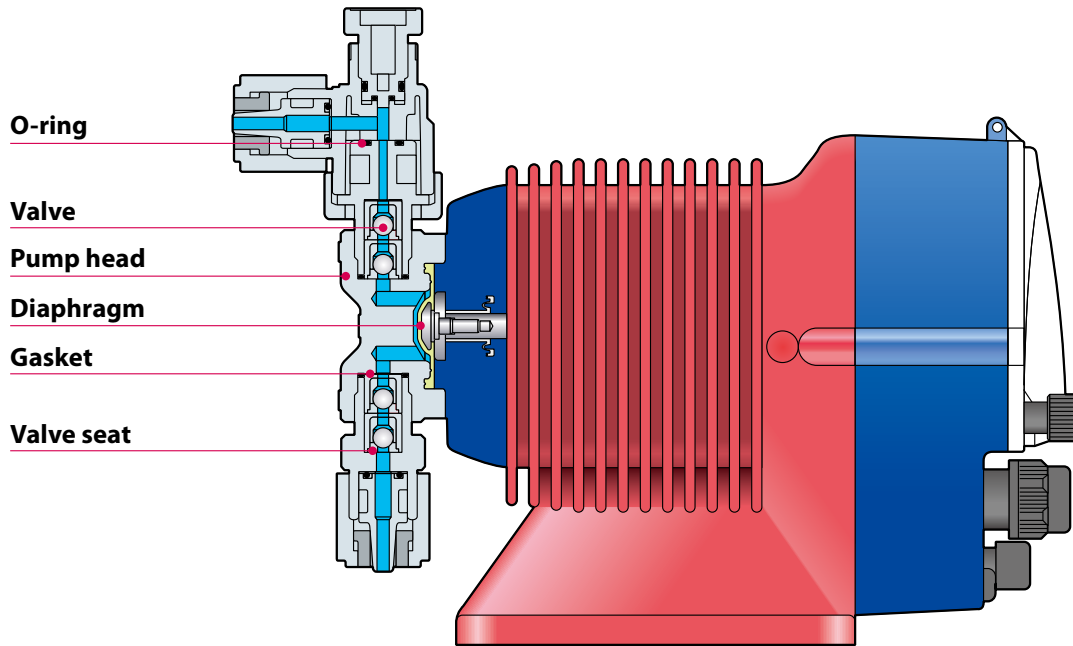

## Wet-End Materials

	Pump head	Valve	Valve seat	O-ring	Diaphragm	Gasket
VC	PVC	Alumina ceramics	FKM	FKM	PTFE+EPDM (EPDM of Diaphragm is not wet-end.)	PTFE
VH		HASTELLOY® C276 equivalent	EPDM	EPDM		
VS <sup>Note1</sup>		SUS316 equivalent				
PC	GFRPP	Alumina ceramics	FKM	FKM		
PH		HASTELLOY® C276 equivalent	EPDM	EPDM		
PS <sup>Note2</sup>		SUS316 equivalent				
FC	PVDF	Alumina ceramics	PCTFE	-		
TC			FKM	FKM		
SH	SUS316	HASTELLOY® C276 equivalent	SUS316	-		

Note 1: EWN-B31 and C31, 36 only.

Note 2: EWN-B31 and C31, 36 only.

## Pump Identification

**EWN - B 11 VC □ E Y □**

1                    2                    3                    4                    5                    6                    7                    8

<p><b>1</b> Series name</p> <p><b>2</b> Drive unit symbol (Average power consumption) <b>B:</b> 20W    <b>C:</b> 24W</p> <p><b>3</b> Diaphragm effective diameter <b>09:</b> 8mm    <b>11:</b> 10mm <b>16:</b> 15mm    <b>21:</b> 20mm <b>31:</b> 30mm    <b>36:</b> 35mm</p>	<p><b>4</b> Wet-end material symbol For details, see the table of materials.</p> <p><b>5</b> Connection <b>Blank:</b> Ø4 x Ø6 (B09,B11,B16,B21,C16,C21) Ø9 x Ø12 (B31,C31,C36) For other option, please contact us.</p> <p><b>6</b> Power code <b>E:</b> With European cord <b>A:</b> With Australian cord</p>	<p><b>7</b> Controller function code <b>Y:</b> Y type</p> <p><b>8</b> Special version code <b>C:</b> High compression type <b>H:</b> High pressure type <b>V:</b> Viscosity type</p>
---	--	--

## Specifications of Pump

Model		B11	B16	B21	B31	C16	C21	C31	C36		
									VC/VS/PC/PS	FC/SH/TC	
Capacity	L/hr	2.3	3.9	6.0	12.0	4.8	7.8	16.2	25.2	24.6	
	mL/min	38	65	100	200	80	130	270	420	410	
	mL/shot	0.05 to 0.1	0.09 to 0.18	0.14 to 0.28	0.28 to 0.56	0.09 to 0.22	0.14 to 0.36	0.3 to 0.75	0.47 to 1.17	0.46 to 1.14	
Rated discharge pressure	MPa	1.0	0.7	0.4	0.2	1.0	0.7	0.35	0.2	0.2	
Max. pressure	MPa	(1.4)	(0.8)	(0.5)	-	(1.2)	(0.8)	-	-	-	
Stroke rate	% (spm)	0.1 to 100 (1 to 360)									
Stroke length range	% (mm)	50 to 100 (0.5 to 1.0)				40 to 100 (0.5 to 1.25)					
Current	A	0.8				1.2					
Average power consumption	W	20				24					

- Each discharge capacity shown above is at discharge pressure (stroke length 100%, stroke rate 100%) and increases as a discharge pressure reduces.
- The performance is based on pumping clean water at ambient temperature at rated voltage.
- Liquid temperature -VC/VH types: -10 to 40°C -PC/PH/FC/SH/TC types: -10 to 60°C
- Max pressure is not guaranteed under any discharge condition. Max pressure of PVC type is 1.2MPa. Please contact us for details.

## Specifications of Controller

Model		EWN-Y	With EFS	Without EFS	
Operational mode	MAN control	MAN(Manual)	•	•	0.1-100.0%(1-360spm)
		Feedback control	•	N/A	0.1 - 999.9mL/min 0.001 - 59.994 L/H 0.001 - 15.828 GPH
	EXT control	DIV	N/A	•	/1-9999
		MULT	N/A	•	x1-9999
		Analog rigid	•	•	4-20, 20-4, 0-20, 20-0mA proportional control to stroke rates
		Analog variable	•	•	2 - point programmable (set point 1 and 2, flow rate or stroke rate)
		BATCH	•	N/A	0.1 - 99999.9 mL 0.001 - 99.999 L 0.001 - 26.385 G
		PLS (pulse operation)	•	•	2 - point programmable (set point 1 and 2, flow rate or stroke rate) <sup>Note 1</sup>
Display	LCD	14seg-5digits backlit LCD Operating conditions and Flow rates etc			
	LED	ON	A 2-color LED lights in orange when turning on power and in green during operation.		
		STOP	A 2-color LED lights in red when receiving the STOP signal and in orange when receiving the PreSTOP signal.		
OUT		A LED lights in red when the pump is transmitting a signal to external devices.			
Keypad	5keys	START/STOP, EXT, ▲(UP), ▼(DOWN), Disp			
Control function	STOP/Pre-STOP	Pump keeps running when Pre-STOP is activated. Pump stops when STOP is activated.			
	Prime	Pump runs at max. stroke rate while up and down keys are pushed.			
	Key lock	Key can be locked and unlocked.			
	Inter lock	Operation stop at contact input <sup>Note 2</sup>			
	Reading calibration	Reading adjustment of flow volume per shot			
	Buffer	ON/OFF of the batch control buffer memory			
Input	Pulse signal input for batch control	No voltage contact or open collector <sup>Note 3</sup>			
	Analogue	0-20mADC (Input resistance is 220Ω.)			
	STOP/Pre-STOP (Level sensor)	No voltage contact or open collector <sup>Note 3</sup>			
	AUX	No voltage contact or open collector <sup>Note 3</sup>			
	Interlock	No voltage contact or open collector <sup>Note 3</sup>			
	Batch	No voltage contact or open collector <sup>Note 3</sup>			
	Pulse	No voltage contact or open collector <sup>Note 3</sup>			
Output	OUT1	No voltage contact (Mechanical relay), 250VAC 3A (Resistive load) Enable or disable the alarms of STOP, Pre-STOP, Interlock, Batch, Out of measurement and Poor flow <sup>Note 4</sup>			
	OUT2	No voltage contact (PhotoMOS relay), AC/DC24V 0.1A Enable or disable the alarms of STOP, Pre-STOP, Interlock, Batch, Out of measurement and Poor flow or Synchronous output (sensor/pump) <sup>Note 3</sup>			
	Analogue	4-20mA DC (Allowable load resistance : 500Ω)			
Data logging	Total flow volume Total number of strokes (1=1000 shots) Total number of signal outputs (OUT1) Total number of signal outputs (OUT2) Total power connection time Total operating time				
Buffer memory	Nonvolatile memory				
Power voltage <sup>Note 5</sup>	100-240VAC 50/60Hz				

- Note 1: The maximum frequency of the input pulse is 500Hz (Duty 50:50).  
 Note 2: The setting can be programmed to "operation starts at contact input".  
 Note 3: The maximum applied voltage from the pump to an external contact is 12V at 2.3mA. When using a mechanical relay, its minimum application load should be 1mA or below.  
 Note 4: STOP/ Pre-STOP/ Interlock/ Batch completion outputs are enabled separately. Output can be programmed to open or close with Alarm.  
 Note 5: Observe the specified power voltage range. Otherwise failure may result. The allowable power voltage range is 90-264VAC

# Optional Accessories

## Sensors

### • EFS flow sensor

The EFS flow sensor is an electromagnetic flow sensor for the electromagnetic metering pump, EWN-Y series. The flow sensor can measure the volume per stroke of pulsating output without the assistance of pulsation dampeners.



### • Constructions and materials

	FT	FH	FF
O ring	FKM	EPDM	FKM
Body	PVDF		
Electrode	Titanium	HASTELLOY® C22 or equivalent	

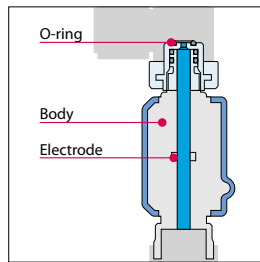

### • Specifications

Applicable pump	EFS-05	EWN-B11, B16, B21, C16, C21-Y
	EFS-10	EWN-C31, C36-Y
Available medium	Minimum conductivity 10mS/cm	
Liquid temp.	0 to 60 °C	

### • Identification

<b>EFS</b>	-	<b>05</b>	<b>FT</b>	<input type="checkbox"/>
1		2	3	4
1 Series symbol		3 Wet-end material symbol See the label of material.		
2 Size : 05, 10		4 Special configuration code		

### • Dimensions in mm

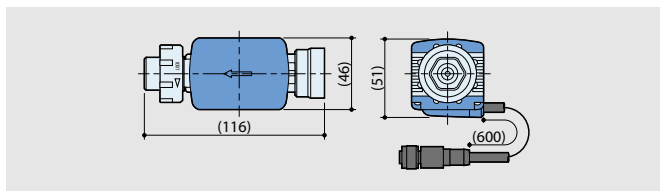

### • FCP flow counter (Posi-flow)

The FCP flow counter (Posi-flow) detects the pump pulsation by a pressure sensor. This sensor can check not only the number of dosing but also abnormal pressure (Low and high) as pipe clogging, gas-lock or pipe leakage.



### • Constructions and materials

	1PC	1PE	1VC	1VE
O ring	FKM	EPDM	FKM	EPDM
Body	GFRPP		PVC	
Sensor	Ceramic (Al <sub>2</sub> O <sub>3</sub> ) 99.7%			

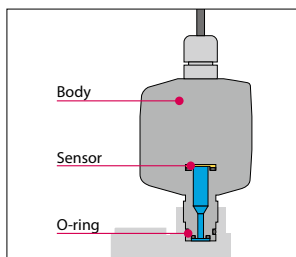

### • Specifications

Applicable pump	EWN-B11, B16, B21, C16, C21
Operating pressure range	0.30 to 1.0 MPa
Indicators	Stop / Error : LED disappears Pressure error : LED lights redly Normal operation : LED lights greenly
Liquid temp.	0 to 40 °C

### • Identification

<b>FCP</b>	-	<b>1</b>	<b>PC</b>
1		2	
1 Series symbol		2 Wet-end material symbol	

### • Dimensions in mm

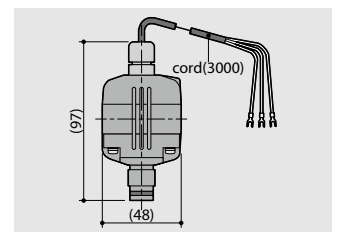

### • FCM flow checker

The FCM is a simple flow checker for the electromagnetic metering pump. A magnet molded float sensor and proximity switch detects pulsation of dosing output.



### • Constructions and materials

	VC	VH
Body	PVC	
Float	PVC	
Plate	PVC	
O ring	FKM	EPDM

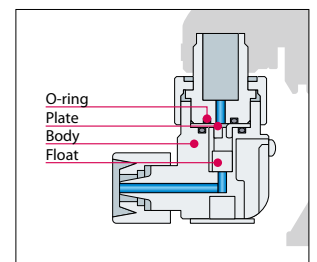

### • Specifications

Power voltage	5-24VDC
Max consumption current	8 mA
Max load capacity	15 mA
Output	NPN Open collector
Frequency	Max 6 Hz
Pulse output range	Min flow rate: 0.1 mL/shot Min discharge pressure: 0.2 MPa Max discharge pressure depends on each pump spec. Pump stroke rate: 1-360 spm Pump stroke length: Fixed to 100% (Factory setting)

### • Identification

<b>FCM</b>	-	<b>VC</b>	<b>1</b>
1		2	3
1 Series symbol		3 Hose connection code (Inn.dia. x Out dia)	
2 Wet-end material symbol		1: Ø4 x Ø9 2: Ø4 x Ø6 7: Ø1/4" x Ø3/8"	

## Accessories

### • Check valve CAN / CBN / CS

This has the function of a non-return valve and prevents siphon and overfeed.

**CAN:** Available in PVC and GFRPP.

**CBN:** In-line type to be connected in the middle of a hose; made of PVC.

**CS:** Made of stainless steel for SH type.



### • Specifications

Model	Connection		Set pressure MPa	Material			Applicable pump			
	Inlet mm	Outlet mm		Body	Spring	O-ring				
<b>CAN-1VC (1V)</b>	4x6, 5x8	R3/8 and R1/2	0.17±0.04	PVC (GFRPP/CFRPP)	HASTELLOY® C276 equivalent	FKM	EWN-B09, 11, 16, 21, C16, 21			
<b>CAN-1VE (1E)</b>	6x8, 6x12					EPDM				
<b>CAN-1VC-H (1E)</b>	4x9, 4x6		FKM							
<b>CAN-1VE-H(1E)</b>	6x8, 1/4"x3/8"		EPDM							
<b>CAN-2VC (2V)</b>	6x12	R3/8 and R1/2	0.17±0.04	PVC (GFRPP/CFRPP)	HASTELLOY® C276 equivalent	FKM	EWN-C31			
<b>CAN-2VE (2E)</b>	9x12					EPDM				
<b>CAN-2VCL (2VL)</b>	6x12	R3/8 and R1/2	0.05 ± 0.03			PVC (GFRPP/CFRPP)		HASTELLOY® C276 equivalent	FKM	EWN-B31, C36
<b>CAN-2VEL (2EL)</b>	9x12								EPDM	
<b>CBN-1VC</b>	4x6, 5x8	6x8, 6x12	0.17±0.04	PVC	HASTELLOY® C276 equivalent		FKM		EWN-B09, 11, 16, 21, C16, 21	
<b>CBN-1VE</b>	6x8, 6x12						EPDM			
<b>CS-1S</b>	Rc1/4	Rc1/4	0.2±0.03	SUS316	HASTELLOY® C276 equivalent	-	EWN-B11, 16, 21, C16, 21, 31			
<b>CS-1SL</b>			0.05±0.03				EWN-B31, C36			

### • Siphon preventing valve BVC

Made of PVC or GFRPP consisting of non-metallic parts.



### • Specifications

Model	Connection		Set pressure MPa	Material		Applicable pump
	Inlet mm	Outlet mm		Body	O-ring	
Note <b>BVC-1</b> □ □	4x6 9x12	R3/8 or R1/2	0.2 or 0.05	PVC	FKM or EPDM	All models

Note: Different models are available. Please contact for particulars.

### • Multi-function valve MFV

This valve has the multi-function of air vent, pressure release inside pipe, pressure relief and back pressure valve



### • Specifications

Model	Tube connection	Set pressure		Material	Applicable pump
		Back pressure valve	Relief valve		
<b>MFV-HTC-2/3/7/23/24</b>	4x6mm, 5x8mm, 6x8mm, 6x12mm, 9x12mm, 10x12mm, 1/4x3/8mm, 3/8x1/2mm	0.25±0.1 MPa	1.25±0.2 MPa	PVDF / FEPM / PTFE+EPDM* (Not a wet end)	B11/B16/C16/C21
<b>MFV-MTC-2/3/7/23/24</b>		0.25±0.1 MPa	0.55±0.1 MPa		B21
<b>MFV-MTC-5/6/8</b>		0.25±0.1 MPa	0.55±0.1 MPa		C31
<b>MFV-LTC-5/6/8</b>		0.1±0.05 MPa	—		B31/C36

### • Foot valve FS / FSP / FSTC

This foot valve with a strainer is made of PVC or GFRPP.



### • Specifications

Model	Tube connection	Material	Applicable pump
<b>FSVN</b>	4x6mm	PVC / FKM / Alumina ceramic	All models
<b>FSEN</b>	5x8mm	PVC / EPDM / SUS316 equivalent	
<b>FSPVN</b>	6x8mm	GFRPP / FKM / Alumina ceramic	
<b>FSPEN</b>	6x12mm	GFRPP / EPDM / SUS316 equivalent	
<b>FSTCN</b>	9x12mm	PVDF / FKM / Alumina ceramic	
<b>FSTCN</b>	10x12mm	PVDF / FKM / Alumina ceramic	

### • Chemical tank EXDT

This is a polyethylene round tank.



**Capacity:** 35, 60, 100, 200 or 300L

### • Priming set PS

Made of PVC furnished with level sensor(s) and foot valve.



### • Specifications

Model	Level switch	Connection mm	Length mm
<b>PS-1</b>	Single	4x6, 5x8, 6x8, 6x12, 9x12	520, 650, 810, 1000, 1350
<b>PS-2</b>	Double		520, 720, 810, 1000, 1350

### • Pulse oscillating flow meter



### • Specifications

Connection	Max. capacity	Range of pulse
3/4"	5m³/h	1xOutput pulse against 0.25L
		1xOutput pulse against 0.50L
		1xOutput pulse against 1.00L
1"	12m³/h	1xOutput pulse against 0.25L
		1xOutput pulse against 0.50L
		1xOutput pulse against 1.00L
1 1/2"	20m³/h	1xOutput pulse against 0.25L
		1xOutput pulse against 0.50L
		1xOutput pulse against 1.00L

Dimensions in mm

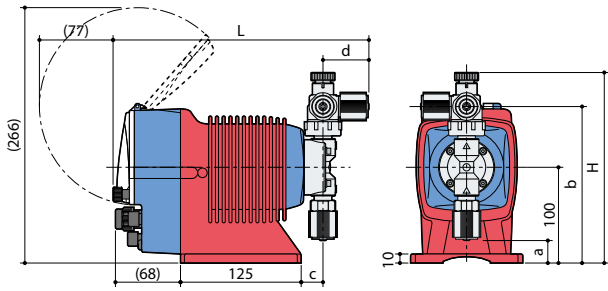

VC/VH/VS

Model	H	L	a	b	c	d
EWN-11, 16, 21	(199)	(265)	(24)	(164)	(23)	(47)
EWN-31	(212)	(267)	(6)	(177)	(25)	(48)
EWN-36	(211)	(267)	(7)	(176)	(24)	(48)

TC

Model	H	L	a	b	c	d
EWN-11, 16, 21	(198)	(265)	(25)	(163)	(23)	(47)
EWN-31	(211)	(267)	(7)	(176)	(25)	(48)
EWN-36	(211)	(268)	(6)	(176)	(24)	(49)

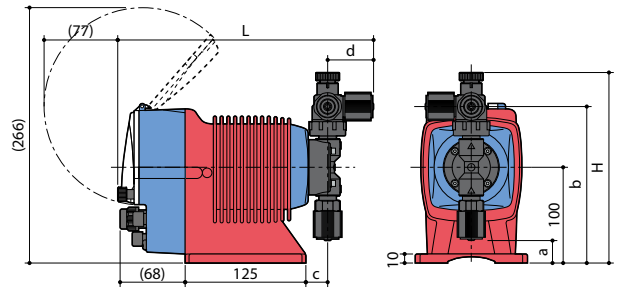

PC/PH/PS

Model	H	L	a	b	c	d
EWN-11, 16, 21	(199)	(265)	(24)	(164)	(23)	(47)
EWN-31	(212)	(267)	(6)	(177)	(25)	(48)
EWN-36	(211)	(267)	(7)	(176)	(24)	(48)

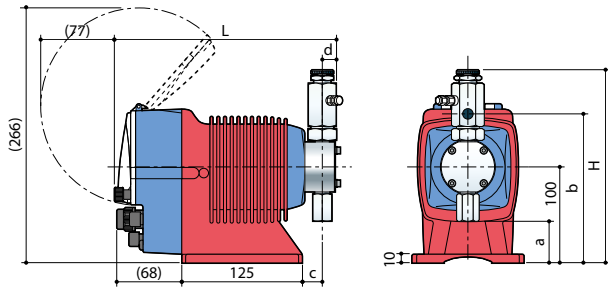

SH

Model	H	L	a	b	c	d
EWN-11, 16, 21	(201)	(232)	(44)	(155)	(22)	(15)
EWN-31	(213)	(233)	(34)	(167)	(23)	(15)
EWN-36	(216)	(233)	(32)	(170)	(23)	(15)

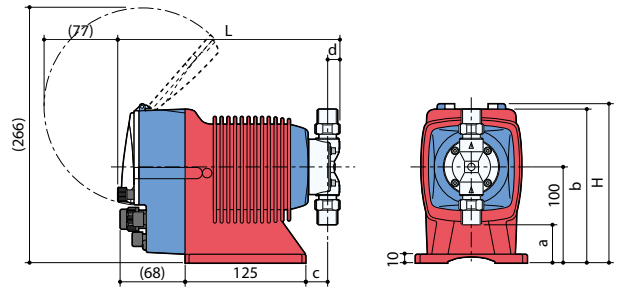

FC

Model	H	L	a	b	c	d
EWN-11, 16, 21	(166)	(231)	(40)	(160)	(23)	(13)
EWN-31	(177)	(236)	(23)	-	(25)	(16)
EWN-36	(177)	(235)	(23)	-	(24)	(16)

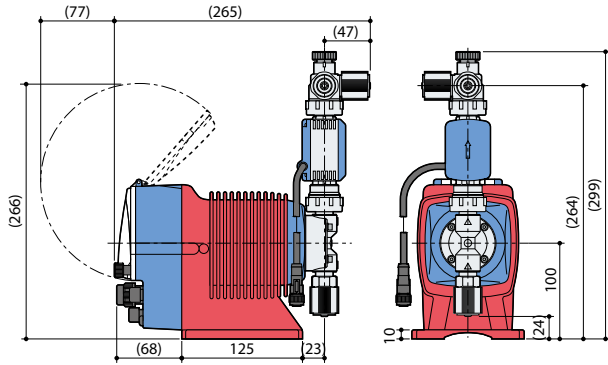

+EFS

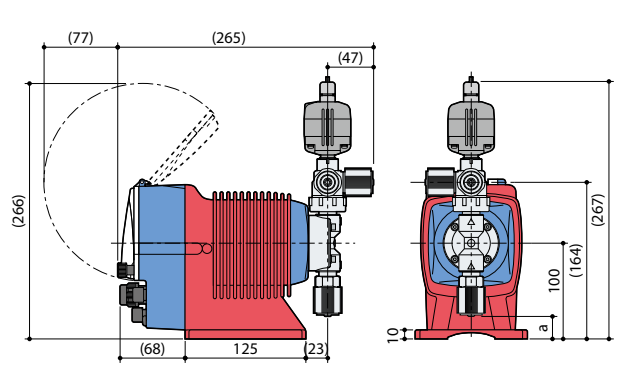

+FCP

IWAKI CO., LTD. 6-6 Kanda-Sudacho 2-chome Chiyoda-ku Tokyo 101-8558 Japan TEL : (81)3 3254 2935 FAX : 3 3252 8892

IWAKI has global net work. Please find your distributor location at

[www.iwakupumps.jp](http://www.iwakupumps.jp)

European Headquarter  
Germany  
The Netherlands (Netherlands Branch)  
Italy (Italy Branch)  
Spain (Spain Branch)  
Poland (East Europe Branch)  
Denmark  
Finland  
Norway  
Sweden  
Belgium  
France

IWAKI Europe GmbH  
IWAKI Europe GmbH  
IWAKI Europe GmbH  
IWAKI Europe GmbH  
IWAKI Europe GmbH  
IWAKI Nordic A/S  
IWAKI Suomi Oy  
IWAKI Norge AS  
IWAKI Sverige AB  
IWAKI Belgium N.V.  
IWAKI France S.A.

TEL: (49)2154 9254 0 FAX: (49)2154 9254 48  
TEL: (49)2154 9254 50 FAX: (49)2154 9254 55  
TEL: (31)74 2420011 FAX: (49)2154 9254 48  
TEL: (39)0445 561219 FAX: (39)0445 569088  
TEL: (34)934 741 638 FAX: (34)934 741 638  
TEL: (48)12 347 0755 FAX: (48)12 347 0900  
TEL: (45)48 242345  
TEL: (358)10 201 0490  
TEL: (47)23 38 49 00  
TEL: (46)8 511 72900  
TEL: (32)13 670200 FAX: (32)13 672030  
TEL: (33)1 69 63 33 70 FAX: (33)1 64 49 92 73

U.S.A.  
Brazil  
China (Shanghai)  
China (Hong Kong)  
China (Guangzhou)  
Singapore  
Indonesia (Indonesia Office)  
Malaysia  
Korea  
Taiwan  
Thailand  
Australia

IWAKI America Inc.  
IWAKI Do Brasil Comercio De Bombas Hidraulicas LTDA.  
IWAKI Pumps (Shanghai) Co., Ltd.  
IWAKI Pumps Co., Ltd.  
GFTZ IWAKI Engineering & Trading Co., Ltd.  
IWAKI Singapore Pte Ltd.  
IWAKI Singapore Pte Ltd.  
IWAKim SDN. BHD.  
IWAKI Korea Co.,Ltd.  
IWAKI Pumps Taiwan Co., Ltd.  
IWAKI (Thailand) Co.,Ltd.  
IWAKI Pumps Australia Pty Ltd.

TEL: (1)508 429 1440 FAX: (1)508 429 1386  
TEL: (55)19 3244 5900 FAX: (55)19 3244 5900  
TEL: (86)21 6272 7502 FAX: (86)21 6272 6929  
TEL: (852)2607 1168 FAX: (852)2607 1000  
TEL: (86)20 84350603 FAX: (86)20 84359181  
TEL: (65)6316 2028 FAX: (65)6316 3221  
TEL: (62)21 6906606 FAX: (62) 21 6906612  
TEL: (60)3 7803 8807 FAX: (60)3 7803 4800  
TEL: (82)2 6238 4800 FAX: (82)2 6238 4801  
TEL: (886)2 8227 6900 FAX: (886)2 8227 6818  
TEL: (66)2 322 2471 FAX: (66)2 322 2477  
TEL: (61)2 9899 2411 FAX: (61)2 9899 2421

( ) Country codes

Caution for safety use: Before use of pump, read instruction manual carefully to use the product correctly. Actual pumps may differ from the photos. Specifications and dimensions are subject to change without prior notice. For further details please contact us.

Legal attention related to export. Our products and/or parts of products fall in the category of goods contained in control list of international regime for export control. Please be reminded that export license could be required when products are exported due to export control regulations of countries. The posting and copying from this catalogue without permission is not accepted firmly.