



**Magnetic drive pump  
resistant to abnormal operations**

Patent

JAPAN / U.S.A. / EU / CHINA / TAIWAN

**The Heart of Industry**

# Even better dry-running resistance and efficiency than previous models. Iwaki MX magnetic drive pumps - reliable & energy efficient.



## Self-radiating structure

Through heat-dispersion holes provided in the fixed portions of the impeller and the magnet capsule, the liquid around the spindle and the bearing is forced to circulate so that heat generated by sliding can be reduced effectively. Thus, thermal deformation and melt are prevented.

(Except MX-70, 100)



## Robust structure

All stress bearing portions, such as the front and rear casings, are reinforced by means of ribs to improve the pressure resistance and the mechanical strength of the pump.

The bearing is not only fixed by conventional press fit but is also sandwiched between the abutting portion in the depth of the magnet capsule and the rear end of the impeller to improve its reliability under high temperature.

(Except MX-70, 100)

MX-402(H), 403(H) and 505 models: an unplugging preventive lock pin is adopted for ensuring more steady securing.



## Enhanced suction characteristics and pump efficiency (PAT. )(MX-505)

Lineup of MX-505 with dramatically improved suction characteristics and pump efficiency, while maintaining the original durable structure.



## Volute casing divided into two sections

The series is the first resin magnet pump which uses the pump casing divided into the front casing and the rear casing to form a vortex chamber as an ideal form. Therefore, the internal leak phenomenon, which means that the liquid getting out of the impeller returns to the pump casing, is suppressed to a minimum and the liquid is efficiently guided to the discharge port to enhance overall efficiency. (Except MX-70/400/505)



## Non-contact structure

By installing the driving magnet and the driven magnet in an inventive way, the movement of the magnet capsule is controlled by magnetic force to prevent the rear thrust and the rear portion of the bearing coming into contact with each other continuously even during dry running. This structure reduces heat generation and secures lubricant routes. (Except MX-70, 100)



MX-505

MX

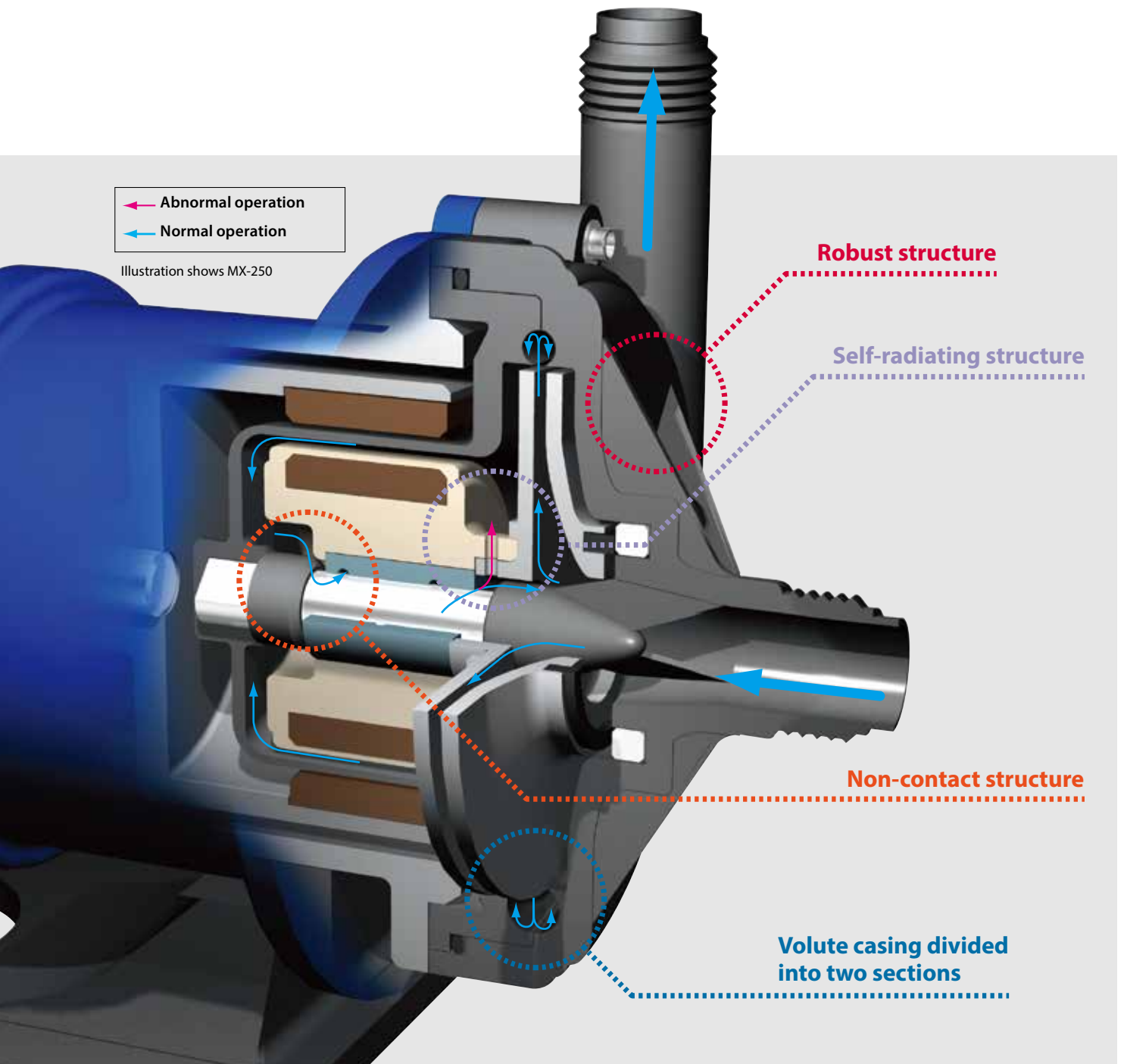

# Wet end materials

## ■ MX-70,100

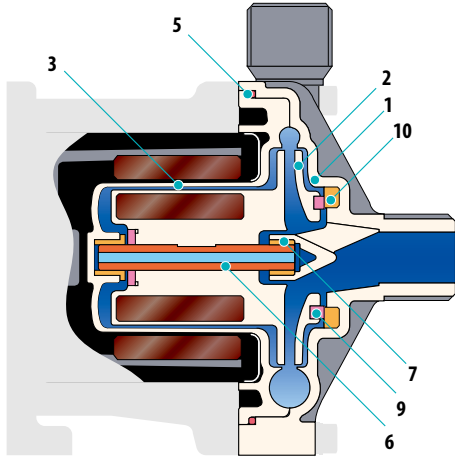

## ■ MX-250 to 401

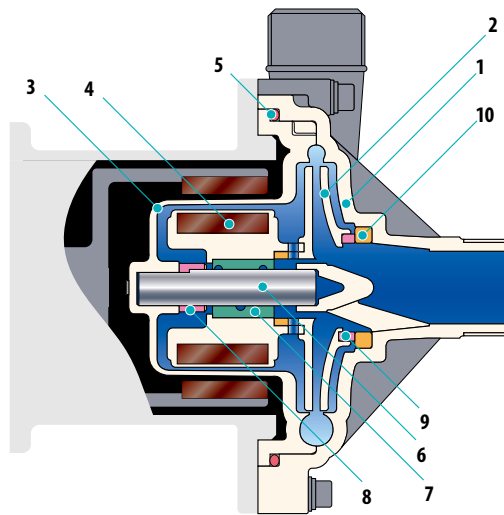

## ■ MX-402 to 403H

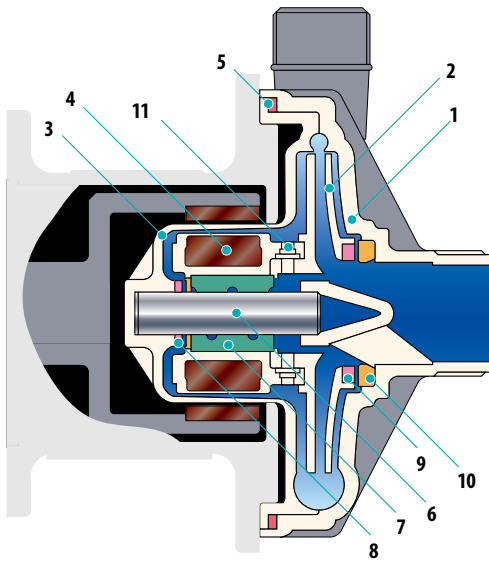

## ■ MX-505

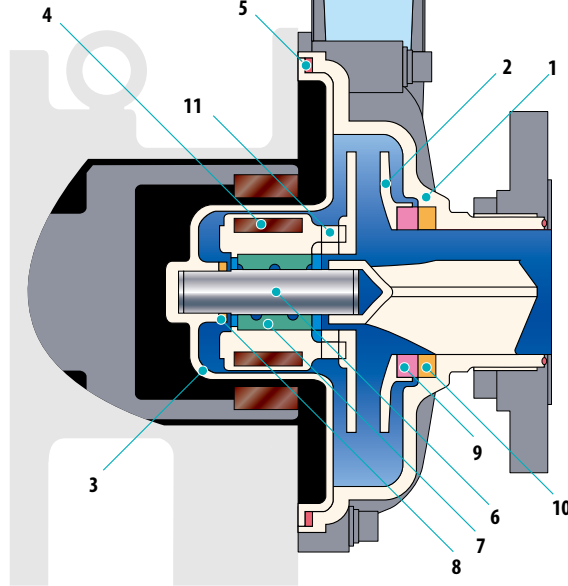

Model	MX-70	MX-100	MX-250 to 505		MX-250 to 401
Mark	V/E		CV/CE	RV/RE	AV/AE
1 Front casing	GFRPP		GFRPP		
2 Impeller	CFRPP				
3 Rear casing	GFRPP		GFRPP		
4 Magnet capsule	-		PP		
5 O ring	FKM(EPDM)		FKM(EPDM)		
6 Spindle	Alumina ceramic		Alumina ceramic		
7 Bearing	PPS	PTFE(with filler)	Carbon	PTFE(with filler)	Alumina ceramic
8 Rear thrust	-		CFRETFE		
9 Mouth ring	-	PTFE(with filler)	PTFE(with filler)		
10 Thrust/Liner ring	Alumina ceramic		Alumina ceramic		
11 Lock pin	-		GFRPPS(Only available type 402 to 505)		-

Note: An O-ring made of AFLAS® is also available

## Pump identification

<b>MX-70 and 100</b>		<b>MX</b> - <b>100</b> <b>V</b> <b>M</b> - <b>34</b>
<b>1</b>	<b>2</b>	<b>3</b>
<b>1</b> Series symbol <b>MX</b> : Material of Casing/GFRPP	<b>2</b> Pump size <b>70</b> : G1X G1 150W <b>100</b> : G1X G1 260W	<b>3</b> Materials <b>MX V</b> : FKM (O-ring) <b>E</b> : EPDM (O-ring)
		<b>4</b> Connection <b>M</b> : Thread connection
		<b>5</b> Motor <b>13</b> : 1 phase 220V/240V <b>34</b> : 3 phase 400/440V

<b>MX-250 to 505</b>		<b>MX</b> - <b>250</b> <b>CV</b> <b>5</b> <b>E</b> - <b>S</b>
<b>1</b>	<b>2</b>	<b>3</b>
<b>1</b> Series symbol <b>MX</b> : Material of Casing/GFRPP	<b>2</b> Pump size <b>250</b> : G1 X G1 0.37kW <b>251</b> : G1 X G1 0.75kW <b>400</b> : G1 1/2 X G1 1/2 0.37kW <b>401</b> : G1 1/2 X G1 1/2 0.75kW <b>402, 402H</b> : G2 X G1 1/2 1.5kW <b>403, 403H</b> : G2 X G1 1/2 2.2kW <b>505</b> : 65A X 50A 4.0kW	<b>3</b> Material of Bearing/Spindle/O-ring <b>MX CV,CE</b> : Carbon/Alumina ceramic/FKM(EPDM) <b>RV,RE</b> : PTFE(with filler)/Alumina ceramic/FKM(EPDM) <b>AV,AE</b> : Alumina ceramic/Alumina ceramic/FKM(EPDM)
		<b>4</b> Impeller mark <b>MX 5</b> : 50Hz <b>7</b> : 50Hz <sup>Note</sup>
		<b>5</b> Motor specification <b>E</b> : IEC motor
		<b>6</b> Special specification: No mark : Standard <b>S</b> : Order-made specification

Note: "7" means exclusive IE2 motor. Applicable models are MX-250/251, 400 & 401.

## Specifications <sup>(50Hz)</sup>

Model	Connection Suction X Discharge	Limit of S.G. <sup>Note1</sup>	Standard capacity L/min - m	Maximum capacity L/min <sup>Note3</sup>	Motor kW	Mass kg <sup>Note4</sup>
MX-70	G1xG1 <sup>Note2</sup>	1.2	50 - 5.4	90	0.15	6.5
MX-100	G1xG1 <sup>Note2</sup>	1.2	70 - 6	110	0.26	8.2
MX-250 (Impeller mark: 5)	G1xG1	1.0	50 - 14	150	0.37	7.7
MX-250 (Impeller mark: 7)			50 - 11.7			
MX-251 (Impeller mark: 5)	G1xG1	1.0	80 - 19	150	0.75	10.2
MX-251 (Impeller mark: 7)						
MX-400 (Impeller mark: 5)	G1 1/2 x G1 1/2	1.2	100 - 10.5	280	0.37	6.2
MX-400 (Impeller mark: 7)			100 - 9.5			
MX-401 (Impeller mark: 5)	G1 1/2 x G1 1/2	1.2	150 - 14.5	320	0.75	10.2
MX-401 (Impeller mark: 7)						
MX-402	G2 x G1 1/2	1.2	200 - 20	450	1.5	13.5
MX-402H	G2 x G1 1/2	1.0	100 - 30	160	1.5	13.5
MX-403	G2 x G1 1/2	1.2	250 - 23	500	2.2	14.5
MX-403H	G2 x G1 1/2	1.0	100 - 35	300	2.2	14.5
MX-505	65Ax50A	1.2	500 - 24.5	800	4.0	27.0

Note1: The specific gravity limit varies with the discharge. For details, please contact us.

Note2: 26mm tube connection option available on the MX-70 and MX-100.

Note3: AV(AE) type is different in discharge capacity. For details, please contact us.

Note4: Less motor except MX-70 and 100.

### Common specifications

• Range of liquid temperature : 0 to 80°C (10 to 80°C in case AFLAS® O-rings are used.) • Range of ambient temperature : 0 to 40°C.

# Performance curves

50Hz

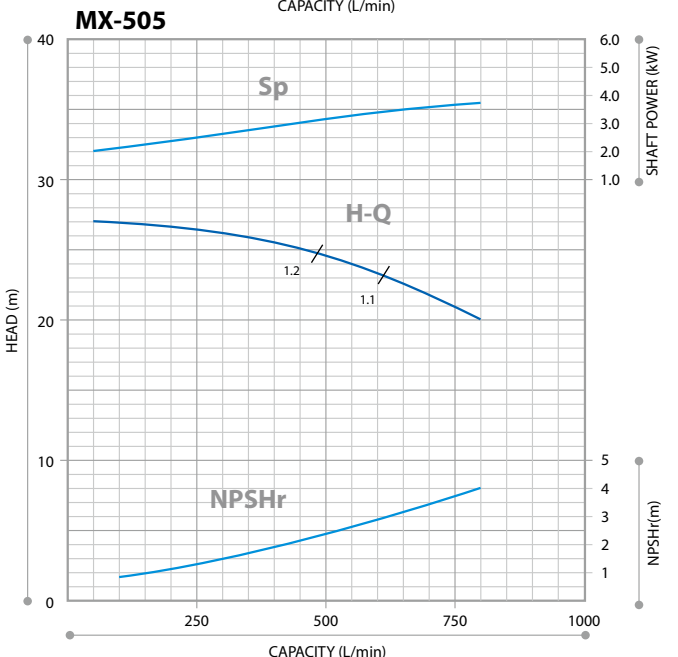
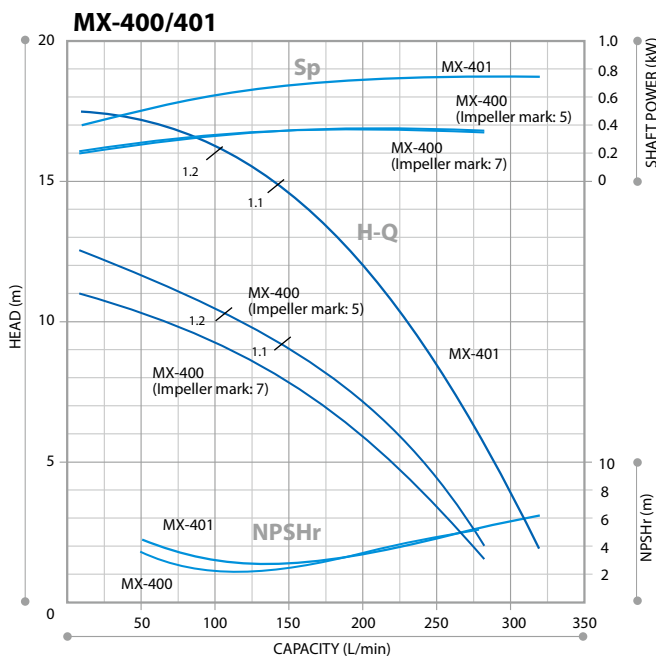
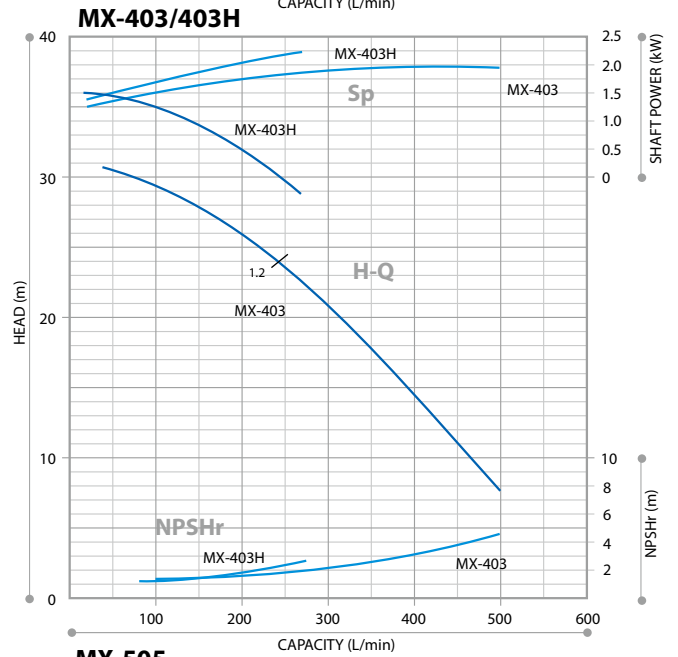
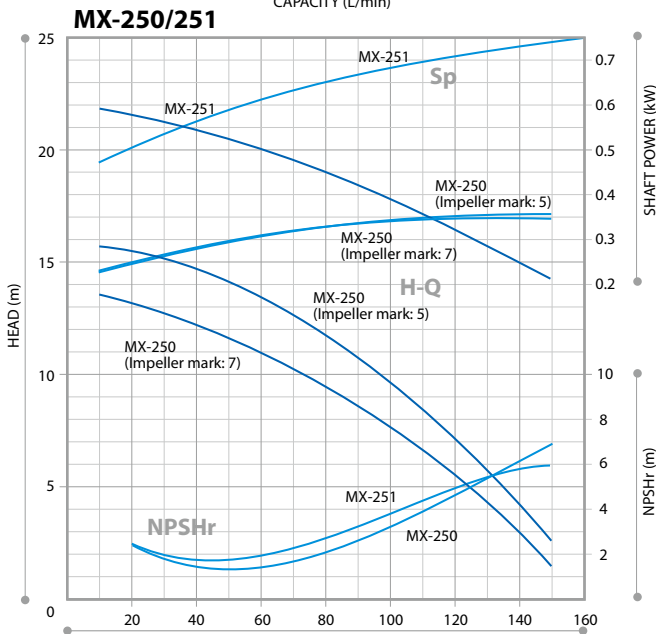
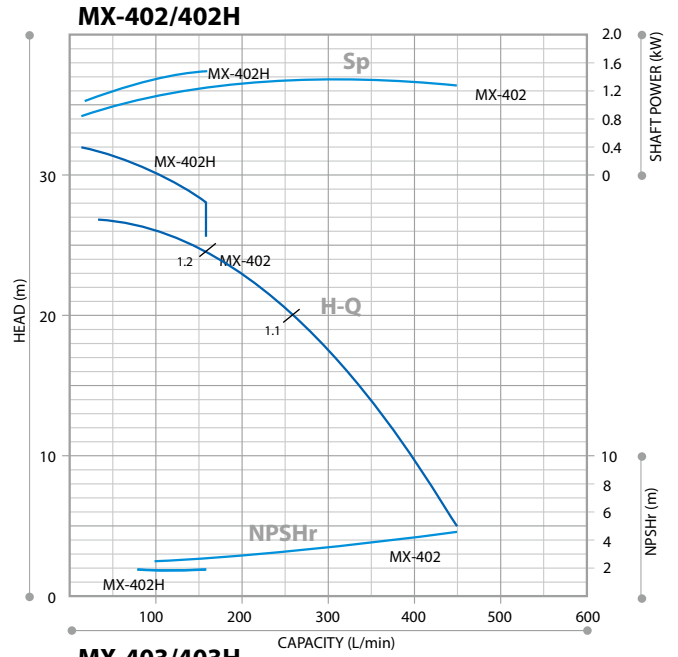
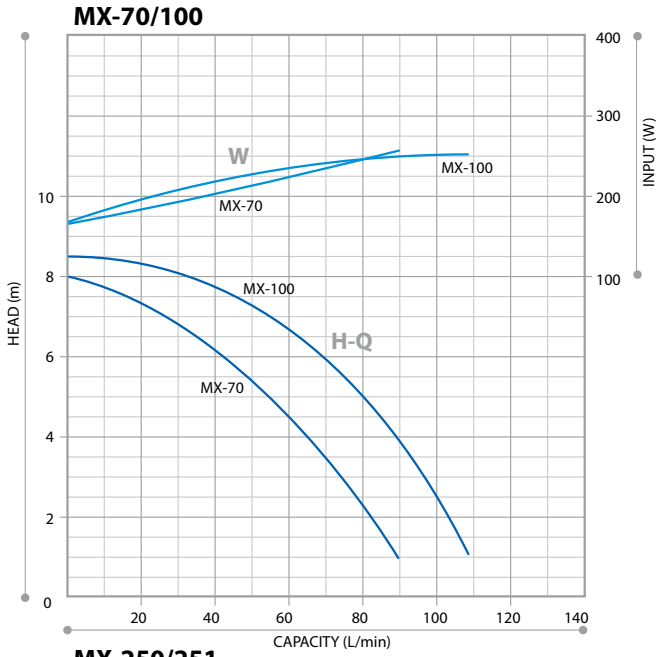

## Dimensions (mm)

### ■ MX-70, 100 Note

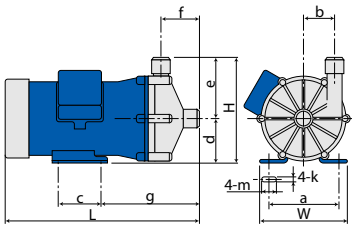

### ■ MX-250 to 401

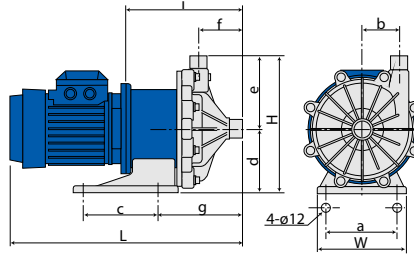

### ■ MX-402, 402H, 403, 403H

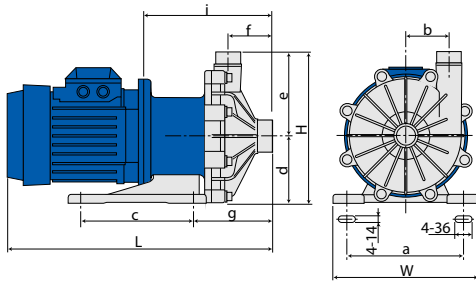

### ■ MX-505

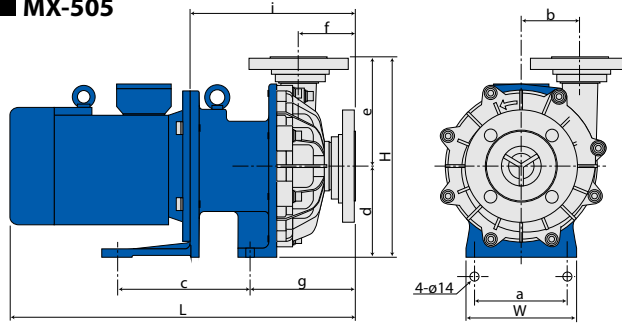

Models	W	H	L	a	b	c	d	e	f	g	k	m	i
MX-70	130	155	258.5	110	48	40	65	90	53	159.5	7	11	–
MX-100	150	175	319.5	110	51	70	75	100	65	162	9	27	–
MX-250	160	247.5	–	130	65	130	115	132.5	82.5	155.5	–	–	213.5
MX-251	160	247.5	–	130	65	130	115	132.5	82.5	163.5	–	–	225.5
MX-400	140	219	–	110	54	98	95	124	81	144	–	–	215
MX-401	160	249	–	130	72	130	115	134	97	178	–	–	240
MX402, 402H	260	274	–	208	80	200	120	154	83	151	–	–	235
MX403, 403H	260	274	–	208	80	200	120	154	83	151	–	–	235
MX-505	180	330	–	140	96	220	150	180	95	175	–	–	275

Note: MX-70 and MX-100 show thread type in the above dimensions, Please contact us for tube connection type.

## Optional accessories

### Iwaki pump protector DRN series

#### Detects unusual pump operating conditions including dry-running and overload

The DRN model protects equipment (including pumps) from damage!

Minimizes production downtime.

Identifies possible causes of alarms so they can be investigated and addressed.

Multiple Input	Two analog, one digital, one temperature input and one current input
Easy operation	Equipped with EASY setup mode to remember the operation status and set the lower/upper limit values, as well as AUTO setup mode
Bar graph	Visible indication of current operating status
Logging capability	Data log feature for preventative maintenance scheduling
Communication	RS485 external communication capability



#### Specifications

Model	DRN-01	DRN-02
Amperometric range	0.5-30.00A	5.0-200.0A
Unit's source voltage	AC100-240V 50/60Hz 10VA	
Operating temperature	0-40°C	
Operating humidity	35-85%RH	

## Iwaki process magnetic drive pump series

### MX-F series

Withstands difficult operating conditions and offers high efficiency

Max. discharge capacity: 510 L/min  
Max. discharge head: 30 m  
Main materials: CFRETFE



### SMX series

Versatile self-priming magnetic drive pump with enhanced durability under abnormal operation

Max. discharge capacity: 440 L/min  
Max. head: 25.5 m  
Main materials: GFRPP, CFRETFE



### MXM series

Magnetic drive pumps with an excellent balance of features and performance

Max. discharge capacity: 600 L/min  
Max. head: 29 m  
Main materials: CFRETFE



### MDM series

Magnetic drive processing pump with dry running capability

Max. discharge capacity: 1800L/min  
Max. head: 74 m  
Main materials: CFRETFE, PFA



IWAKI CO., LTD. 6-6 Kanda-Sudacho 2-chome Chiyoda-ku Tokyo 101-8558 Japan TEL : (81)3 3254 2935 FAX : 3 3252 8892

IWAKI has global net work. Please find your distributor location at

[www.iwakipumps.jp](http://www.iwakipumps.jp)

European Headquarter	: IWAKI Europe GmbH	TEL: (49)2154 9254 0	FAX: 2154 9254 48	U.S.A.	: IWAKI America Inc.	TEL: (1)508 429 1440	FAX: 508 429 1386
Germany	: IWAKI Europe GmbH	TEL: (49)2154 9254 50	FAX: 2154 9254 55	Argentina	: IWAKI America Inc. (Argentina Branch)	TEL: (54)11 4745 4116	
The Netherlands	: IWAKI Europe GmbH (Netherlands Branch)	TEL: (31)74 2420011	FAX: (49)2154 925448	Brazil	: IWAKI Do Brazil Comercio De Bombas Hidraulicas LTDA.	TEL: (55)19 3244 5900	FAX: 19 3244 5900
Italy	: IWAKI Europe GmbH (Italy Branch)	TEL: (39)0444 371115	FAX: 0444 335350	Singapore	: IWAKI Singapore Pte Ltd.	TEL: (65)6316 2028	FAX: 6316 3221
Spain	: IWAKI Europe GmbH (Spain Branch)	TEL: (34)93 37 70 198	FAX: 93 47 40 991	Indonesia	: IWAKI Singapore (Indonesia Office)	TEL: (62)21 6906606	FAX: 21 6906612
Poland	: IWAKI Europe GmbH (East Europe Branch)	TEL: (48)12 347 0755	FAX: 13 67 20 30	Malaysia	: IWAKIm Sdn. Bhd.	TEL: (60)3 7803 8807	FAX: 3 7803 4800
Belgium	: IWAKI Belgium N.V.	TEL: (32)13 67 02 00	FAX: 12 347 0900	Australia	: IWAKI Pumps Australia Pty Ltd.	TEL: (61)2 9899 2411	FAX: 2 9899 2421
Denmark	: IWAKI Nordic A/S	TEL: (45)48 24 2345		China (Hong Kong)	: IWAKI Pumps Co., Ltd.	TEL: (852)2607 1168	FAX: 2607 1000
Finland	: IWAKI Suomi Oy	TEL: (358)9 2745810		China (Guangzhou)	: GFTZ IWAKI Engineering & Trading Co., Ltd.	TEL: (86)20 84350603	FAX: 20 84359181
France	: IWAKI France S.A.	TEL: (33)1 69 63 33 70	FAX: 1 64 49 92 73	China (Shanghai)	: IWAKI Pumps (Shanghai) Co., Ltd.	TEL: (86)21 6272 7502	FAX: 21 6272 6929
Norway	: IWAKI Norge AS	TEL: (47)23 38 49 00		Korea	: IWAKI Korea Co., Ltd.	TEL: (82)2 2630 4800	FAX: 2 2630 4801
Sweden	: IWAKI Sverige AB	TEL: (46)8 511 72900	( )Country codes	Taiwan	: IWAKI Pumps Taiwan Co., Ltd.	TEL: (886)2 8227 6900	FAX: 2 8227 6818
				Thailand	: IWAKI (Thailand) Co.,Ltd.	TEL: (66)2 322 2471	FAX: 2 322 2477



Caution for safety use:

Before use of pump, read instruction manual carefully to use the product correctly.

Actual pumps may differ from the photos. Specifications and dimensions are subject to change without prior notice. For further details please contact us.



Legal attention related to export.

Our products and/or parts of products fall in the category of goods contained in control list of international regime for export control. Please be reminded that export license could be required when products are exported due to export control regulations of countries.

The posting and copying from this catalogue without permission is not accepted firmly.