

Item	Description	Q'ty	Type	Material	Part No.	Code No.	
100.1	Front Casing+Liner Ring Unit	1	CF•FF	CFRETFE+Ceramic	MXM0264	1210042810	
		1	KK	CFRETFE+SiC	MXM0265	1210042820	
100.2	Cover 'A/B' Unit (ISO)	1		Ductile Iron	MXM0318	1220306020	
100.4	Cover 'C' Unit (ISO)	1		Ductile Iron	MXM0319	1220306220	
122.1	Air Vent/Drain Cap (M14x2)	2		ETFE	MXM0114	1240644600	
158	Rear Casing	1	H	CFRETFE	MXM0266	1231191200	
159	Rear Casing Cover	1	H	FRP	MXM0173	1231190200	
210	Spindle	1	CF	Alumina Ceramic	MX0118	1240725000	
		1	KK	SiC	MX0427	1240765100	
230	Impeller <1> [1XF]	Ø 115 mm	1	1151	CFRETFE	MXM0291	1240861920
		Ø 110 mm	1	1101	CFRETFE	MXM0292	1240861930
		Ø 100 mm	1	1001	CFRETFE	MXM0294	1240861950
		Ø 90 mm	1	0901	CFRETFE	MXM0296	1240861960
	Impeller <2> [2XF]	Ø 128 mm	1	1302	CFRETFE	MXM0299	1231199710
310	Bearing	1	CF	High Density Carbon	MX0475	1240764800	
		1	KK	SiC	MX0476	1240764900	
	<210+310> Spindle+Bearing Unit	1	FF	Alumina Ceramic	MXM0339	2270270210	
314.2	Mouth Ring	1	CF•FF	PTFE	MX0208	1240752800	
		1	KK	SiC	MX0472	1240393300	
314.3	Rear Thrust	1		CFRETFE	MX0428	1240764700	
330	Frame	0,75•1,5kW	1	441•442-H	MXM0302	1210043120	
400.1	O-Ring <G-160>	1	V	FKM-A	MXM0305	0325300186	
		1	E	EPDM	MXM0306	0325300187	
		1	A	Aflas®	MXM0307	0325300195	
		1	P	DAI-EL Perfluoro®	MXM0308	0325300283	
400.2	Gasket (t: 2mm, Ø 12mm)	2	V	FKM	MXM0009	1240010300	
		2	E	EPDM	MXM0010	1240014200	
		2	A	Aflas®	MXM0011	1240102200	
		2	P	DAI-EL Perfluoro®	MXM0015	1240465900	

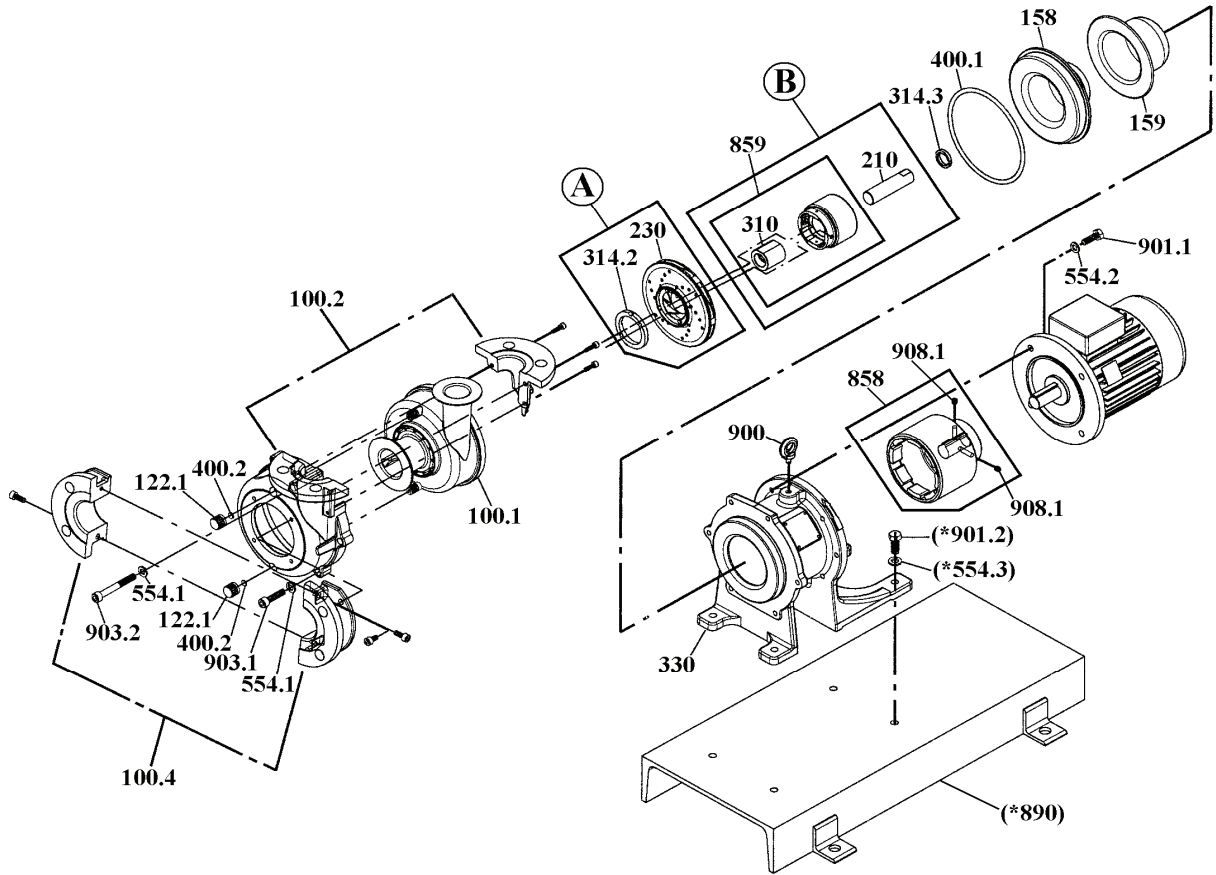

Item	Description	Q'ty	Type	Material	Part No.	Code No.	
858	Drive Magnet Unit (with 2x908.1)	0,75kW [XMJ41H]	1	441-H	Ductile Iron+Mag.	MXM0300	1231191500
		1,5kW [XJ2H]	1	442-H	Ductile Iron+Mag.	MXM0067	1220300000
859	Magnet Capsule+ Bearing Assembly	0,75kW	1	441-CF	CFRETFE+Carbon	MX0443	1231022110
			1	441-KK	CFRETFE+SiC	MX0445	1231022130
		1,5kW	1	442-CF	CFRETFE+Carbon	MXM0267	1231196510
			1	442-KK	CFRETFE+SiC	MXM0269	1231196530
554.1	Spring Washer (Cover 'A/B') M10	6		SUS304 equivalent	MDM0030	0154100022	
554.2	Spring Washer (Motor) M10	4	441•442	SUS304 equivalent	MDM0030	0154100022	
900	Eye Bolt (Frame) M10	1		Steel		0150800002	
901.1	Hex. Bolt (Motor) M10x25	4	441•442	SUS304 equivalent	MDM0041	0150100181	
903.1	Cap Bolt (Cover 'A/B') M10x55	3		SUS304 equivalent	MXM0303	0150300047	
903.2	Cap Bolt (Cover 'A/B') M10x75	3		SUS304 equivalent	MXM0304	0150300051	
908.1	Setscrew (Drive Mag.Unit) M8x10	2	441•442	Steel	MDM0044	0152100046	
A	Impeller <1> + Mouth Ring Assembly	Ø 115 mm	1	1151-CF•FF	CFRETFE+PTFE	MXM0271	1240861320
		Ø 110 mm	1	1101-CF•FF	CFRETFE+PTFE	MXM0272	1240861330
		Ø 100 mm	1	1001-CF•FF	CFRETFE+PTFE	MXM0274	1240861350
		Ø 90 mm	1	0901-CF•FF	CFRETFE+PTFE	MXM0276	1240861360
	Impeller <2> + M.R. "	Ø 128 mm	1	1302-CF•FF	CFRETFE+PTFE	MXM0279	1240861210
		Impeller <1> + Mouth Ring Assembly	Ø 115 mm	1	1151-KK	CFRETFE+SiC	MXM0281
	Ø 110 mm		1	1101-KK	CFRETFE+SiC	MXM0282	1240861630
	Ø 100 mm		1	1001-KK	CFRETFE+SiC	MXM0284	1240861650
Ø 90 mm	1		0901-KK	CFRETFE+SiC	MXM0286	1240861660	
Impeller <2> + M.R. "	Ø 128 mm	1	1302-KK	CFRETFE+SiC	MXM0289	1240861510	
B	Mag. Capsule+Bearing +Spindle Set	0,75kW	1	441-FF	CFRETFE+Ceramic	MXM0337	2270270010
		1,5kW	1	442-FF	CFRETFE+Ceramic	MXM0336	2270269910
*890	Base	1	"B"	Steel	MXM0309	1231210300	
*554.3	Spring Washer (Base) M12	4	"B"	SUS304 equivalent	MDM0029	0154100024	
*901.2	Hex. Bolt (Base) M12x30	4	"B"	SUS304 equivalent	MDM0042	0150100206	

Note: Items asterisked (*) are optional parts.

△ Subject to change without prior notice! △ Actual pump may differ from the exploded view!