

IWAKI Magnetic Drive Pump

MX-F100

Instruction Manual

 Read this manual before use of product

Thank you for selecting an Iwaki MX-F type Magnetic Drive Pump. This instruction manual deals with "Safety Instructions", "Outline", "Installation", "Operation" and "Maintenance" sections.

Please read through this instruction manual to ensure the optimum performance, safety and service of your pump.

Contents

Safety Instructions	1
<i>Outline</i>	
1. Unpacking & Inspection	3
2. Operating principle	3
3. Identification code	4
4. Specification	4
5. Outer dimensions	5
6. Performance curves	6
7. Overview & Label	6
8. Part names & Structure	7
<i>Installation</i>	
1. Before installation	9
2. Installation/Piping/Electrical wiring	11
<i>Operation</i>	
1. Before operation	14
2. Operation	14
<i>Maintenance</i>	
1. Troubleshooting	17
2. Maintenance & Inspection	17
3. Drainage	18



This instruction manual should be kept on hand by the end user for quick reference.

Contact us or your nearest dealer if you have any questions.



Important Instruction

For the Safe and Correct Handling of the Pump

- "Safety Instruction" section deals with important details about handling of the product. Before use, read this section carefully for the prevention of personal injury or property damage.
- Observe the instructions accompanied with "WARNING" or "CAUTION" in this manual. These instructions are very important for protecting pump users from dangerous situations.
- The symbols on this instruction manual have the following meanings:

 WARNING	Nonobservance or misapplication of the contents of "Warning" section could lead to a serious accident which may result in death.
 CAUTION	Nonobservance or misapplication of the contents of "Caution" section could lead to a personal injury or damage to the product.

Types of Symbols

	Indicates a prohibited action or procedure. Inside or near this circle, a concrete and practical image of the activity to be avoided is depicted.
	Indicates an important action or procedure which must be performed or carried out without fail. Failure to follow the instructions herein can lead to malfunction or damage to the pump.

For exportation

Technology related to the use of goods in this instruction manual falls in the category of technology contained in the Foreign Exchange Order Attachment, which includes complementary export control of technology. Please be reminded that export license, which is issued by the Ministry of Economy, Trade, and Industry could be required, when this is exported or provided to someone even in Japan.

Safety Instructions

WARNING

- **Turn off the power.**

Risk of electrical shock. Dismantling/assembling the pump unit without turning off the power may cause an electrical shock. Before engaging in any maintenance or inspection work, be sure to turn off the pump and related devices.



Power off

- **Terminate operation.**

On sensing any abnormal sign, stop operation immediately and inspect/solve problems.



- **For specified application only**

The use of the pump in any application other than those clearly specified may result in injury or damage. Use the pump in a specified condition.



Prohibited

- **No dismantlement/modification**

Do not dismantle/modify the pump. We are not responsible for any accidents or damage due to modification.



No modification
No dismantlement

- **Wear protective clothing.**

Always wear protective clothing such as safety goggles and protective gloves during pipework or dismantlement.



Wear protectors

CAUTION

- **Restriction on operator**

The pump should be handled by a qualified person with a full understanding.



Prohibited

- **Specified power only**

Do not apply any power other than the specified one on the nameplate. Otherwise damage or fire may result.



Prohibited

- **Do not place the pump close to water.**

The pump is not dust-/water-proof construction. The use of the pump in a humid place or a place where the pump can get wet may result in electrical shock or short-circuit.



Prohibited

- **Ventilation**

Poisoning may result when handling a toxic or odorous liquid. Keep good ventilation in your operating site.



Caution

- **Countermeasure against efflux**

Take a protective measure against the accidental efflux caused by pump or pipe breakage.



Caution

- **Do not use a damaged pump.**

Using a damaged pump may lead to an electric leak or shock.



Prohibited

Safety Instructions

CAUTION

- **Do not run pump dry.**
If the pump runs without a liquid, the pump is damaged by friction heat.
- **Do not damage the power cable.**
Risk of fire or electrical shock. Do not scratch, modify, or pull the power cable. The cable can also be damaged when it is heated or loaded with a heavy thing.
- **Earthing**
Risk of electrical shock. Always earth the pump.
- **Do not pressurize the pump over the maximum discharge pressure.**
A leak may result from the sealing surface of O ring or the pump fails at worst.
- **Install an earth leakage breaker.**
An electrical failure of the pump may adversely affect related devices. Purchase and install an earth leakage breaker separately.



Prohibited



Caution



Earthing



Prohibited



Electrical shock

CAUTION

- **Power cable is not replaceable.**
Do not use any damaged power cable for the prevention of a fire or electrical shock. The cable is not replaceable, so that the whole pump unit needs to be replaced when the cable is damaged.
- **Limited operating site and storage**
Do not install or store the pump in the following places where...
 1. Ambient is beyond 0 and 40°C.
 2. Under a flammable/corrosive atmosphere.
- **Disposal of the used pump**
Dispose of any used or damaged pump in accordance with relevant regulations. Consult a licensed industrial waste products disposing company.
- **Static electricity**
When low electric conductivity liquids such as ultra-pure water and fluor inactive liquid (e.g. Fluorinert™) are handled, the static electricity may generate in the pump and may cause static discharge. Take counter-measures to remove the static electricity.



Electrical shock



Prohibited



Outline

Before use, check the specification, limitation and hazardous nature of the pump.

1. Unpacking & Inspection

On unpacking the product, check the following points. If you find any problems, contact your nearest dealer.

1. Check the information on the name-plate such as model code, discharge capacity, discharge head and voltage to see that the product is delivered as per order.

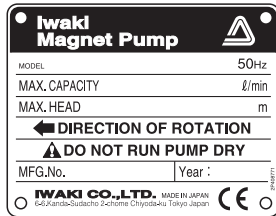

2. Check for transit damage, deformation, and loose bolts.

2. Operating principle

The MX-F is a magnetic drive centrifugal pump with fluoroplastic and fine ceramic wet ends and is capable of handling a strong acid and alkali.

The magnetic force between drive and driven magnets rotates the impeller in the pump chamber, where a liquid is transferred from the inlet to outlet.

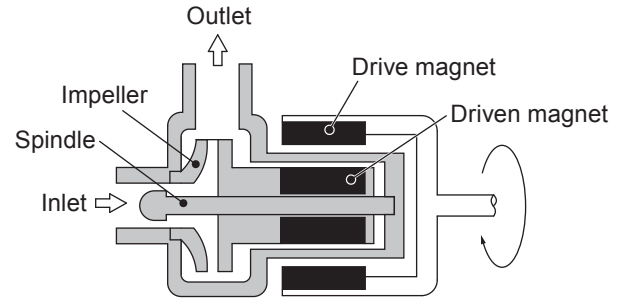

Outline

3. Identification code

MX-F - 100 V M Y - 32
 a b c d e f

- a. Series
CFRETFE casing material
- b. Pump size
100
- c. Wet end material
RV : PTFE (bearing)/ FKM (O ring)
KV : SiC (bearing)/ FKM (O ring)
- d. Inlet/Outlet
M : Thread connection (G1)
FL : Flange connection (25A)
- e. Impeller
Y : 50Hz
- f. Motor power voltage
No code : 1 phase 100V
32 : 3 phases 200/220V

4. Specification

50Hz

Model	Max flow (L/min)	Max head (m)	Norm flow (m-L/min)	Max SG	Motor		Mass (kg)
					Power (V)	Rated output (W)	
MX-F100Y	110	8.2	5.8-70	1.9	100	260	8.5
					200 or 220		

Model	Thread connection		Flange connection	
	Inlet	Outlet	Inlet	Outlet
MX-F100 (M/FL)	G1		25A	

NOTE:

- a. Performance data is based on pumping of clear water at ambient temperature.
- b. Allowable liquid temperature is 0-80°C (non-freezing). Note that the temperature range may change with liquid property. Avoid a precipitous fluctuation of temperature even in the liquid temperature range above.
- c. The maximum head is a shutoff head. Note that shutoff operation is not allowed (do not keep a discharge line closed for more than 1 minute in operation), or it may adversely affect a life period.
- d. The maximum specific gravity is obtained at the maximum flow and changes with a duty point, room-/liquid-temperatures and liquid viscosity.
- e. Single-phase capacitor-start induction motor or 3-phase motor is selectable
- f. See the specification label on the pump for detail info.
- g. Performance and dimension are subject to change without prior notice.

5. Outer dimensions

MX-F100M

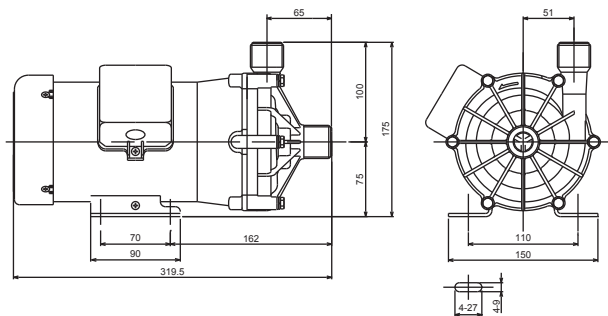

MX-F100FL

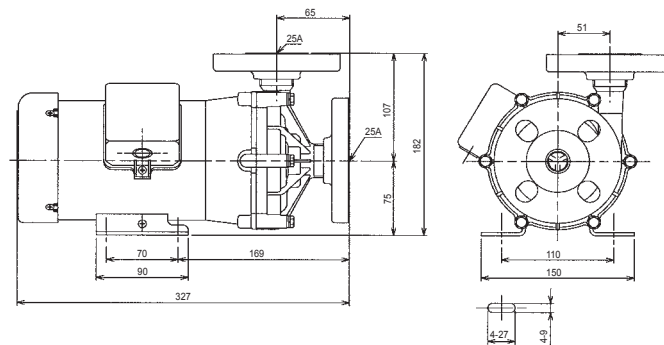

Outline

6. Performance curves

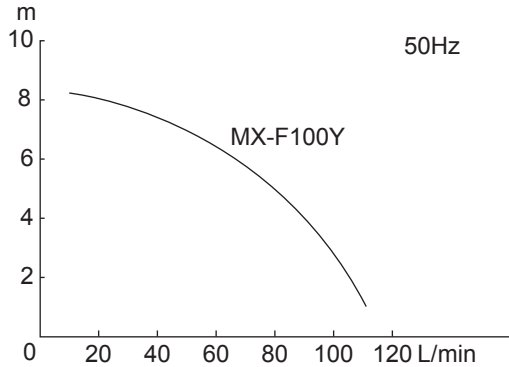

*Performance data is based on pumping of clear water at ambient temperature.

7. Overview & Label

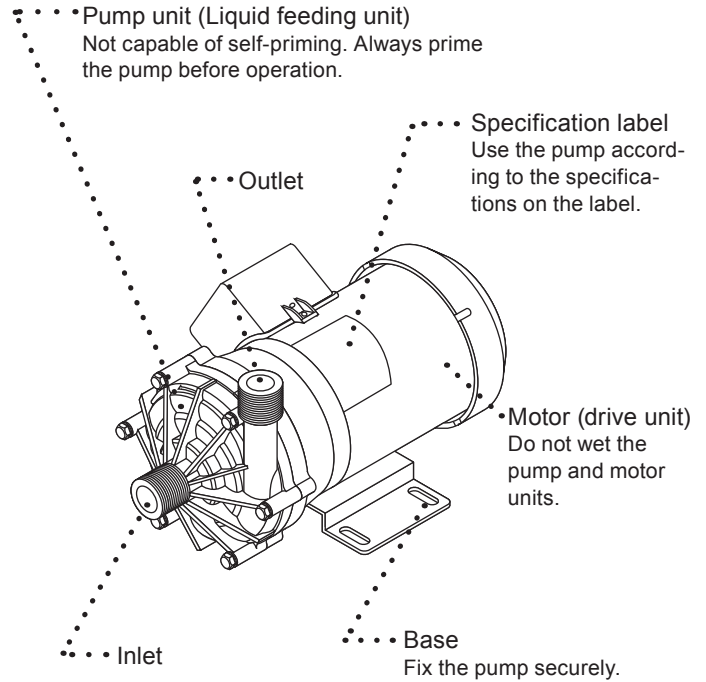

Outline

8. Part names & Structure

MX-F100M

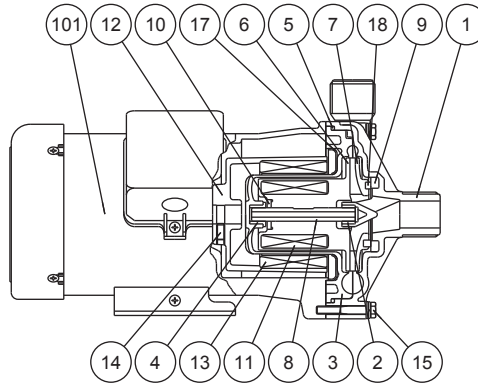

No.	Part names	Q'ty	Materials	
			MX-F100RV	MX-F100KV
1	Front casing	1	CFRETFE	
2	Bearing A	1	PTFE	SiC
3	Rear casing	1	CFRETFE	
4	Bearing B	1	PTFE	SiC
5	O ring	1	V:FKM E: EPDM	
6	Impeller	1	CFRETFE	
7	Shroud	1	CFRETFE	
8	Spindle	1	Alumina ceramics	SiC
9	Front thrust ring	1	Alumina ceramics	-

No.	Part names	Q'ty	Materials	
			MX-F100RV	MX-F100KV
10	Rear thrust ring	1*	Alumina ceramics	SiC
11	Driven magnet	1		
12	Drive magnet unit	1		
13	Drive magnet	1		
14	Hex. sock set screw	2	Steel	
15	Hex. head bolt	6	Stainless steel	
17	Retainer ring	1	SUS304	
18	Mouth ring	1	PTFE	-
101	Motor	1		

*The MX-F100KV has two impeller thrust rings.

CFRETFE : Carbon Fiber Reinforced Ethylene Tetra Fluoro Ethylene
 SiC : Silicon Carbide
 FKM : Fluoroelastomer

Outline

MX-F100FL

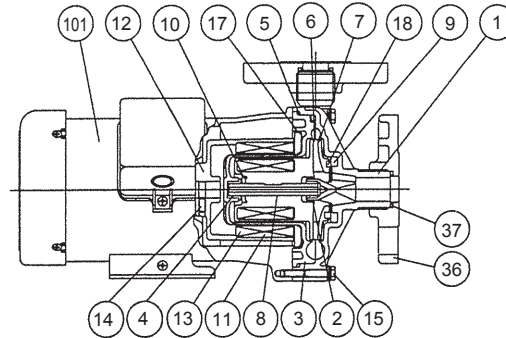

No.	Part names	Q'ty	Materials
			MX-F100RVFL
1	Front casing	1	CFRETFE
2	Bearing A	1	PTFE
3	Rear casing	1	CFRETFE
4	Bearing B	1	PTFE
5	O ring	1	V:FKM E: EPDM
6	Impeller	1	CFRETFE
7	Shroud	1	CFRETFE
8	Spindle	1	Alumina ceramics
9	Front thrust ring	1	Alumina ceramics
10	Rear thrust ring	1*	Alumina ceramics

*The MX-F100KV has two impeller thrust rings.

No.	Part names	Q'ty	Materials
			MX-F100RVFL
11	Drive magnet	1	
12	Drive magnet unit	1	Ferrite magnet + Aluminium alloy
13	Driven magnet	1	
14	Hex. sock set screw	2	Steel
15	Hex. head bolt	6	Stainless steel
17	Retainer ring	1	SUS304
18	Mouth ring	1	PTFE
36	Flange	2	PTFE
37	O ring	2	FKM
101	Motor	1	

CFRETFE : Carbon Fiber Reinforced Ethylene Tetra Fluoro Ethylene
FKM : Fluoroelastomer

Installation

1. Before Installation

Read through this section before use. Carry out installation work with a full understanding.

WARNING

- Risk of electrical shock. Turn off power immediately after the pump or any electric parts have got wet.
- Risk of fire. Keep the pump away from a flammable substance.

CAUTION

- A strong magnet is inside the pump. Do not bring a watch or floppy disk which may be adversely affected by a magnetic force.
- Do not run pump dry. If the pump runs without a liquid, friction heat damages the pump.

- Dropping or subjecting the pump to strong impact, failure may result. Handle the pump with care.

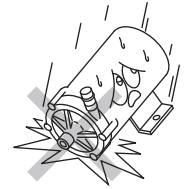

- The pump is not capable of self-priming. Always prime the pump before operation.

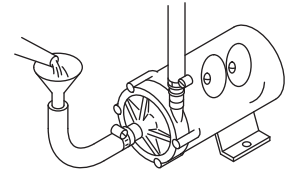

- Do not get the motor wet. The pump is not dust-/water-proof.

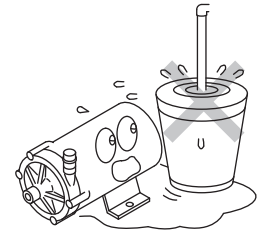

- Risk of fire or electrical shock. Do not scratch, modify, or pull the power cable. The cable can also be damaged when it is heated or loaded with a heavy thing.

Installation

- Banned solutions
 - Liquids that significantly swell polypropylene
 - Paraffinic hydrocarbons such as gasoline and kerosene.
 - Halogenated hydrocarbons such as trichloroethylene and carbon tetrachloride
 - Ether and low-grade ester
 - Slurry (Never use slurry, which wears out the pump bearings.)

- A strong magnet is inside the pump. Do not use the pump with any liquid which contains metals such as iron and nickel.

Iron or nickel

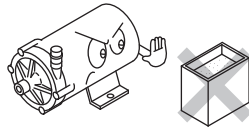

Benzine or thinner

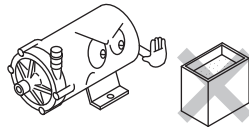

- Do not use any damaged pump. Using a damaged pump may lead to an electric leak or shock.

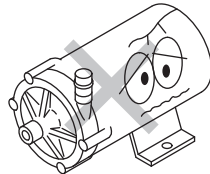

⚠ CAUTION

Do not install or store the pump in the following places where...

- Ambient temperature is beyond 0 and 40°C.
- In a dusty or humid place.
- Under direct sunlight or wind & rain.



Installation

2. Installation/ Piping/ Electrical wiring

Stop working upon sensing a danger sign or abnormality in work.

2.1 Installation

1. Installation location

Select a convenient place for maintenance and inspection. Observe the allowable room temperature of 0-40°C and maximum ambient humidity of 90%RH.

2. Mounting position

This pump is not capable of self-priming. Flooded suction application is ideal. Try to install the pump 30cm lower than the suction liquid level.

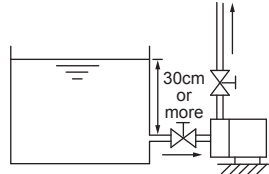

⚠ CAUTION

Air may be introduced into the pump, wearing out bearings excessively if a liquid level in a supply tank is too low.

3. Outlet direction

Always direct the outlet upward, or entrained air can not be expelled.

⚠ CAUTION

Do not mount the pump vertically, directing the pump head upward. Always use corrosion resistant screws for anchoring the pump.

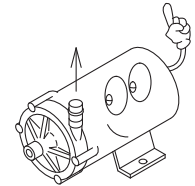

Direct the outlet upward

4. Pump fixation

Secure the pump by fixing the base. Do not install the pump vertically.

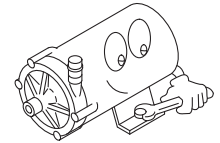

2.2 Piping

1. In order to minimize the piping resistance, have piping shortest with the minimum bends. For the prevention of cavitation, have the suction piping bore wide as much as possible.
2. The pump can be plumbed via thread or flange connection. See a specification table on page 4 for suitable connection.

Installation

3. Install valves on both discharge and suction lines.

- Suction-side valve:
For easy pump removal and maintenance.
- Discharge-side valve:
For adjustment of the flow rate and discharge head.

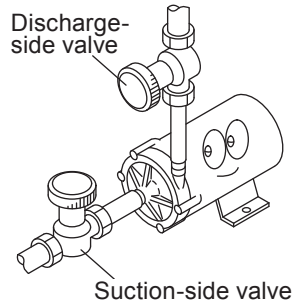

4. Do not allow piping system to weigh heavily on the plastic inlet or outlet, otherwise the plastic parts may deform and result in failure.

5. The MX-F100KV is provided with a cushioning material in outlet. Remove it before pipework.

⚠ CAUTION

Be careful not to drop the pump onto the floor. A strong impact may reduce pump performance.

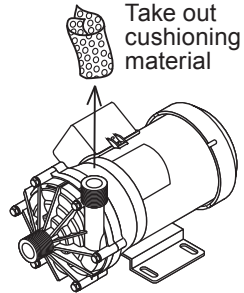

<Thread connection>

Wrap a thread seal tape around the exposed threads of a pipe before it is screwed in to create an air- and water-tight seal.

Use of a Teflon pipe or Teflon-lined pipe is recommended.

⚠ CAUTION

Do not tighten the pipe too much, or plastic inlet or outlet may break.

⚠ CAUTION

Imperfect connection on the suction line introduces air into the inside. Air ingress may cause a poor flow, dry running and consequently impeller seizing.

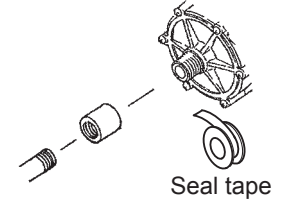

Installation

2.3 Electrical wiring

Electrical wiring must be done by a qualified person who has a full knowledge of safety. We are not responsible for the injury or damage accident due to nonobservance of this warning. Contact us or your nearest dealer for wiring as necessary.

■ Before wiring

1. Confirm that the power is disconnected before work.
2. Wiring work should be done in accordance with the relevant regulations, using the recommended wiring accessories.
3. Apply the specified power voltage. See the spec label.
4. The pump doesn't have the ON-OFF switch. The pump starts as the power cable is plugged in.
5. Earth the pump by an earthing wire. Keep good ventilation in your operating site. Do not wet the pump.
6. When a leakage breaker is used.
Always solve the root cause when a leakage breaker operates. Be sure to unplug the pump before investigation.

■ Rated current & Starting current

Model	Rated current		Starting current	
	100V (1-phase)	200 or 220V (3-phase)	100V (1-phase)	200 or 220V (3-phase)
MX-F100	4.1A	1.2A	8.4A	3.7A

Operation

1. Before operation

Read through this section before use.

CAUTION

- Do not keep a discharge or suction line little open or closed in operation.
- Do not open/narrow a discharge or suction line at once, otherwise the magnetic coupling*¹ may be disconnected*² (In this case turn off the power.).
- If foreign matters enter the pump, turn off the power and remove them, otherwise failure or malfunction may result.
- Do not run pump dry. If the pump runs without a liquid, the pump is damaged by friction heat.

Word & Terms:

*1 A pair of drive and driven magnets

*2 A state that a driven magnet (combination of impeller and magnet capsule units) does not rotate in sync with the drive magnet.

1. Before operation, check the connection between the pump and piping.
2. Check the pump is securely anchored.

2. Operation

The pump doesn't have the ON-OFF switch. The pump starts as the power cable is plugged in. After installation, piping and wiring work are completed, operate the pump in accordance with the following procedures.

■ Operating procedure

No.	Procedure	Points to be checked
1	Check piping, wiring and voltage.	<ul style="list-style-type: none">• See "2.2 Piping" and "2.3 Electrical wiring" sections.• Check the spec label to see if the power supply voltage is correct.
2	Open or close a valve.	<ul style="list-style-type: none">• Fully open a suction-side valve.• Fully close a discharge-side valve.
3*	Prime the pump chamber.	<ul style="list-style-type: none">• Fill the pump chamber with liquid.• In suction lift application, a foot valve is needed to keep liquid in the pump chamber.
4	Supply power to the pump.	<ul style="list-style-type: none">• Check the item 1, 2 and 3. Then turn on power and start the pump.

*If the pump chamber is not filled enough, conduct degassing. See page 15 for detail.

Operation

No.	Procedure	Points to be checked
5	Adjust discharge capacity & discharge head to specified level.	<p>Open a discharge-side valve gradually till the flow and head reach a specified level. <u>Do not open or close the valve at once.</u></p> <p>Note: Do not keep the discharge-side valve closed more than 1 minute.</p> <p>Note: Check that the pump transfers a liquid without trouble. If there is a problem, turn off the power immediately and solve the cause. See "Troubleshooting" section of page 17.</p>
6	Points to be checked during operation	<ul style="list-style-type: none"> Do not allow foreign matters to enter the pump. Foreign matters may cause impeller to be locked, hindering liquid circulation. In this case turn off power immediately (Contact us). Turn off power when the leakage breaker operates. Investigate the root cause on "Troubleshooting" section of page 17.

■ Degassing

Open a discharge line. The end of the line immersed in liquid is not ideal for degassing. Take it out from liquid as necessary. Then run the pump for one second. Repeat the one-second operation from three to five times to expel air completely.

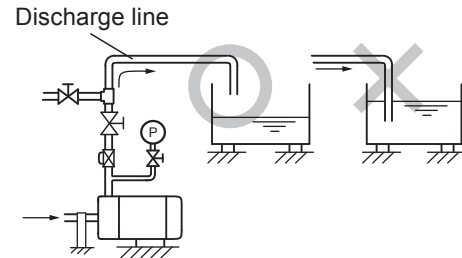

If an air vent line is laid on, open it instead of a discharge line before degassing.

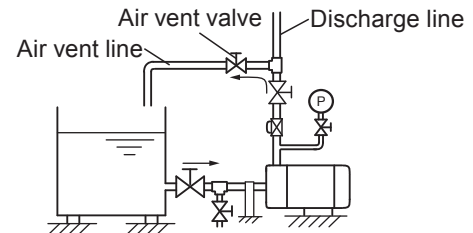

Operation

■ Shutdown

No.	Procedure	Description
1	Close a discharge-side valve.	Close the discharge-side valve gradually. Set closing speed to a slow level when using a solenoid valve.
2	Turn off power.	Check if the motor stops rotating smoothly as turning off power. If it is not smooth, check the motor. Contact us for detail.

■ Before a long period of stoppage

Empty the pump before it is stopped for a long time. In this period of time run the pump with clean water for 5 minutes every 3 months to prevent the motor bearing from being stuck.

Follow the operating procedure on page 14 to resume operation.

Maintenance

1. Troubleshooting

Handling of the pump, maintenance and inspection should be carried out within this instruction manual. Do not handle the pump beyond the descriptions in this manual.

We are not responsible for any personal injury or property damage due to nonobservance of this warning. Contact us or your nearest dealer as necessary.

Phenomenon	The pump does not run.	Poor discharge head	Overcurrent	Noise and vibration problem	Leakage	Measure
Wrong wiring	<input type="radio"/>		<input type="radio"/>			Inspect wiring. Rewire as necessary.
Motor failure	<input type="radio"/>		<input type="radio"/>			Contact us.
Air is trapped.		<input type="radio"/>		<input type="radio"/>		Eliminate air.
Air suction from the inlet		<input type="radio"/>				Check suction piping.
Dry running		<input type="radio"/>	<input type="radio"/>	<input type="radio"/>		Prime the pump before operation.
Too high SG or viscosity	<input type="radio"/>	<input type="radio"/>	<input type="radio"/>			Replace with suitable pump.
Impeller magnet hits the rear casing		<input type="radio"/>	<input type="radio"/>	<input type="radio"/>		Contact us.
Impeller is damaged.	<input type="radio"/>	<input type="radio"/>	<input type="radio"/>	<input type="radio"/>		Contact us.
Foreign matters on the impeller.		<input type="radio"/>	<input type="radio"/>	<input type="radio"/>		Contact us.
O ring is damaged					<input type="radio"/>	Contact us
Pump head mounting screws are loose.		<input type="radio"/>			<input type="radio"/>	Tighten the mounting screws.

2. Maintenance & Inspection

■ Retightening

After a long period of operation or storage, the pump head mounting screws may loosen. Tighten uniformly the mounting screws by 3.4N•m as necessary. Be careful not to deform the plastic pump head.

■ Daily inspection

Always check for abnormality in vibration, noise, current value, and discharge capacity. Stop operation on sensing any abnormal sign. And solve problems on the trouble shooting section.

■ Cleaning

Periodically flush the inside of a supply tank and piping with water to keep clean conditions.

Turn off power before cleaning the pump exterior. Wait until the pump cools down if it is right after operation. Wet a cloth with tap water and wring it out for cleaning the pump. Use a neutral detergent for greasy dirt and then rub with a dry cloth.

Check the pump exterior is dried before a restart.

CAUTION

Do not clean the pump with solvent such as benzene, alcohol and thinner. This may discolour the pump.

CAUTION

Risk of electrical shock or short circuit. Do not wet motor or electrical wiring.

Maintenance

■ Wear parts

To run the pump for a long period, wear parts such as impeller and O ring need to be replaced periodically.

Contact your distributor for detail.

■ Before a long period of storage

Turn off power and empty the pump completely. Protect the pump from dust with cover as necessary.

Do not store the pump any of the following conditions.

- Under a flammable atmosphere
- Under a corrosive atmosphere
- Ambient temperature exceeds 40°C.
- Ambient temperature falls below 0°C.
- Under a dusty or humid space.
- Under direct sunlight
- Under wind and rain
- Under vibration

3. Drainage

The pump does not have a drain port. See next procedure for detail.

WARNING

- Turn off power before work.
- Wear protective clothing such as safety goggles and protective gloves when handling harmful liquid.

CAUTION

- The motor or electric parts are not dust- or water-proof. Do not wet them when removing piping.
- Do not drain a harmful chemical liquid directly on the ground or the floor. Always use a container.

1. Turn off power. Make sure no one turns on the power by mistake while you are working on the pump.
2. Close the discharge- and suction-side valves fully.
3. Place a container under the pump and then remove suction line from the pump inlet.

CAUTION

Be careful not to get wet with chemicals.

4. Unfix and take out the pump.
5. Drain residual chemicals to a container through the inlet.

**IWAKI PUMPS**

()Country codes

IWAKI CO.,LTD. 6-6 Kanda-Sudacho 2-chome Chiyoda-ku Tokyo 101-8558 Japan
TEL:(81)3 3254 2935 FAX:3 3252 8892(<http://www.iwakupumps.jp>)

Australia	IWAKI Pumps Australia Pty. Ltd.	TEL: (61)2 9899 2411	FAX: 2 9899 2421	Italy	IWAKI Italia S.R.L.	TEL: (39)02 990 3931	FAX: 02 990 42888
Austria	IWAKI (Austria) GmbH	TEL: (43)2236 33469	FAX: 2236 33469	Korea	IWAKI Korea Co.,Ltd.	TEL: (82)2 2630 4800	FAX: 2 2630 4801
Belgium	IWAKI Belgium n.v.	TEL: (32)1367 0200	FAX: 1367 2030	Malaysia	IWAKIm Sdn. Bhd.	TEL: (60)3 7803 8807	FAX: 3 7803 4800
China	IWAKI Pumps (Shanghai) Co., Ltd.	TEL: (86)21 6272 7502	FAX: 21 6272 6929	Norway	IWAKI Norge AS	TEL: (47)66 81 1660	FAX: 66 81 1661
China	IWAKI Pumps (Guandong) Co., Ltd.	TEL: (86)750 3866228	FAX: 750 3866278	Singapore	IWAKI Singapore Pte. Ltd.	TEL: (65)6316 2028	FAX: 6316 3221
China	GFTZIWAKI Engineering & Trading (Guangzhou)	TEL: (86)20 8435 0603	FAX: 20 8435 9181	Spain	IWAKI Iberica Pumps, S.A.	TEL: (34)943 630030	FAX: 943 628799
China	GFTZIWAKI Engineering & Trading (Beijing)	TEL: (86)10 6442 7713	FAX: 10 6442 7712	Sweden	IWAKI Sverige AB	TEL: (46)8 511 72900	FAX: 8 511 72922
Denmark	IWAKI Nordic A/S	TEL: (45)48 24 2345	FAX: 48 24 2346	Switzerland	IWAKI (Schweiz) AG	TEL: (41)26 674 9300	FAX: 26 674 9302
Finland	IWAKI Suomi Oy	TEL: (358)9 2745810	FAX: 9 2742715	Taiwan	IWAKI Pumps Taiwan Co., Ltd.	TEL: (886)2 8227 6900	FAX: 2 8227 6818
France	IWAKI France S.A.	TEL: (33)1 69 63 33 70	FAX: 1 64 49 92 73	Taiwan	IWAKI Pumps Taiwan (Hsin-chu) Co., Ltd.	TEL: (886)3 573 5797	FAX: (886)3 573 5798
Germany	IWAKI EUROPE GmbH	TEL: (49)2154 9254 0	FAX: 2154 9254 48	Thailand	IWAKI (Thailand) Co.,Ltd.	TEL: (66)2 322 2471	FAX: 2 322 2477
Holland	IWAKI Holland B.V.	TEL: (31)547 293 160	FAX: 547 292 332	U.K.	IWAKI Pumps (UK) LTD.	TEL: (44)1743 231363	FAX: 1743 366607
Hong Kong	IWAKI Pumps Co., Ltd.	TEL: (852)2 607 1168	FAX: 2 607 1000	U.S.A.	IWAKI AMERICA Inc.	TEL: (1)508 429 1440	FAX: 508 429 1386
Indonesia	IWAKI Singapore (Indonesia Branch)	TEL: (62)21 690 6606	FAX: 21 690 6612	Vietnam	IWAKI pumps Vietnam Co.,Ltd.	TEL: (84)613 933456	FAX: 613 933399

T719 '10/01